

Quick Start Guide

GUIDER II

SZ11-EN-A02

WARNING

-
1. Hot! Avoid touching the heating nozzle in operation.
 2. Moving parts in printer may cause injury. Do not wear gloves or other sources of entanglement in operation.
-

USER GUIDE

The User Guide is in the USB stick.

Kit Contents

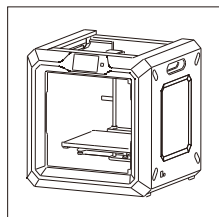

3D Printer

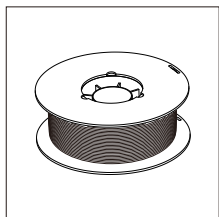

Filament Spool

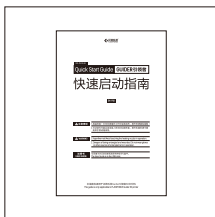

Quick Start Guide



After-sales Service Card

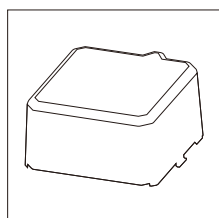

Lid

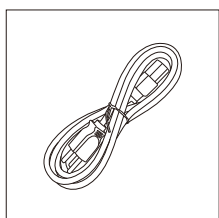

Power Cable

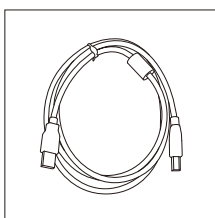

USB Cable

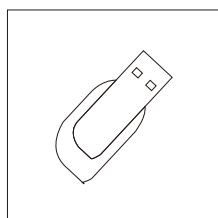

USB Stick

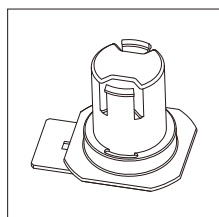

Spool Holder

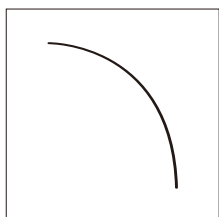

Filament Guide Tube

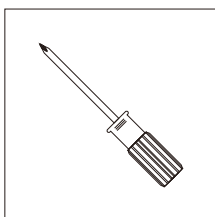

Screwdriver

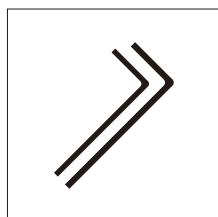

Allen Wrench

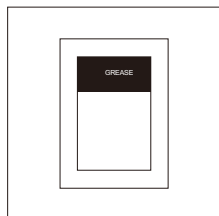

Grease

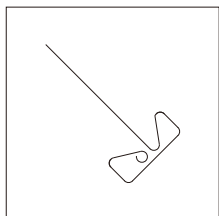

Unclogging Pin Tool

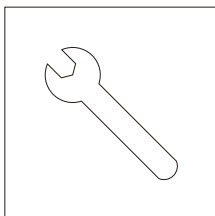

Wrench

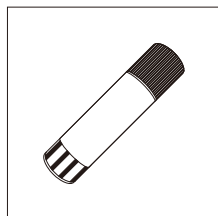

Solid Glue

Getting to Know Your Guider II

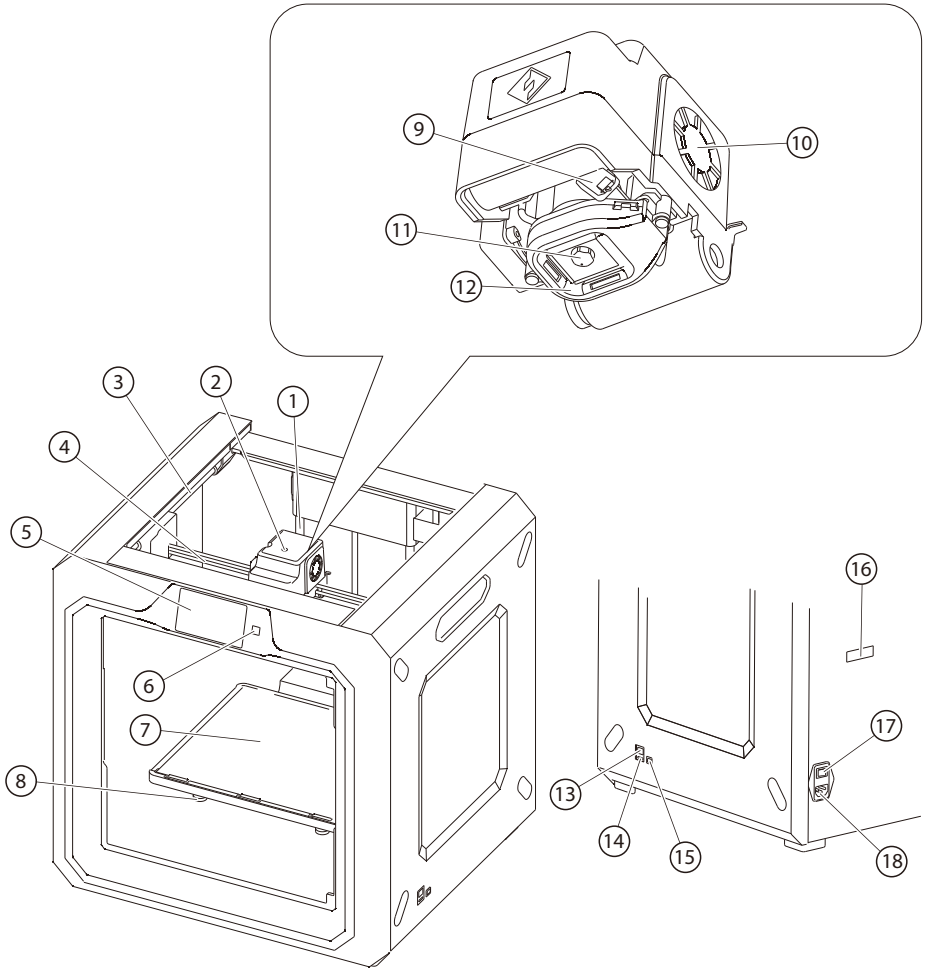

- | | | | |
|-----------------------|------------------------|---------------------|-----------------------|
| 1. Z-Axis Guide Rod | 2. Filament Inlet | 3. Y-Axis Guide Rod | 4. X-Axis Guide Rod |
| 5. Touch Screen | 6. Touch Screen Button | 7. Build Plate | 8. Leveling Knob |
| 9. Servo | 10. Turbo Fan | 11. Nozzle | 12. Turbo Fan Baffle |
| 13. Network Interface | 14. USB Stick Input | 15. USB Cable Input | 16. Spool Holder Slot |
| 17. Power Switch | 18. Power Input | | |

Unpacking



1. Open the box and remove both top foam sheets.



2. Take your Guider II out of the box and remove the bubble wrap.

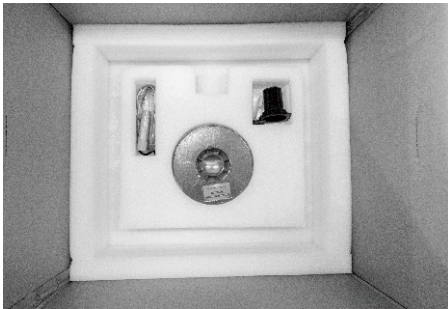

3. The bottom PE foam should contain: filament, spool holder, solid glue, USB cable, grease and accessories bag.



4. Remove bubble wrap.



5. Remove the top PE foam piece, which contains a power cable, a Quick start guide and a After-sales service card.

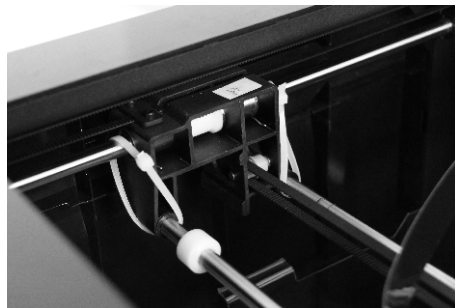

6. Use scissors to cut the buckles that hold the rods in the place.

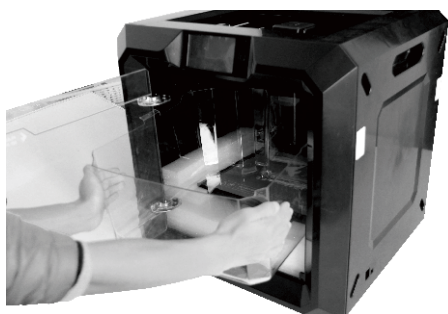

7. Open the door and take out the lid.

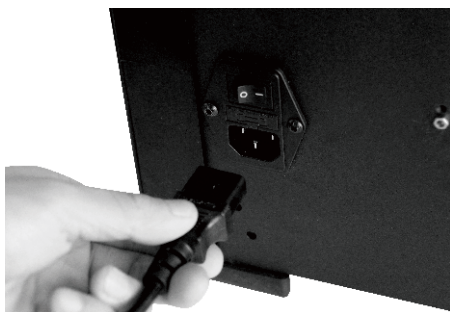

8. Take out power cable and plug the power cable into the input on the back and turn on the power switch.

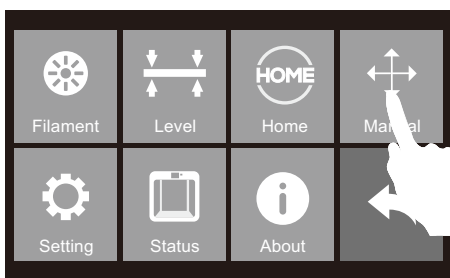
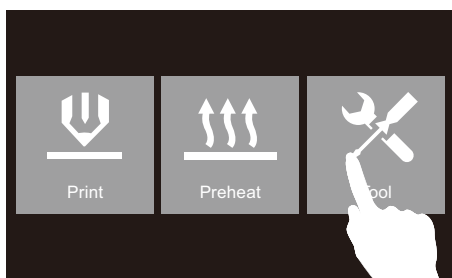

9. Press the touch screen button and tap [Tools] .10. Tap [Manual].

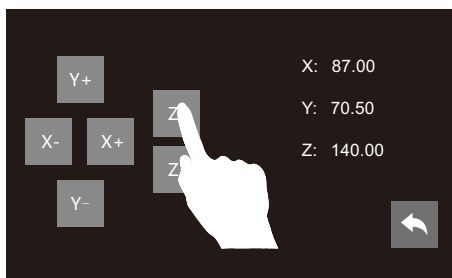

11. Tap [Z-] to partially elevate the build plate.

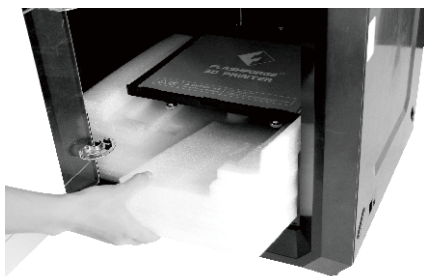

12. Remove both bottom foam pieces. Congratulations! You've unpacked your Guider II.

Hardware Assembly

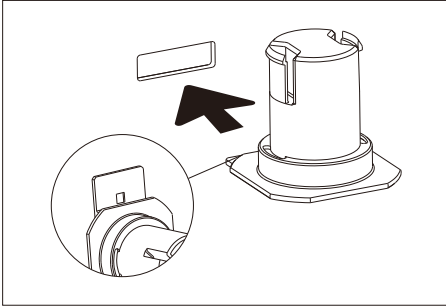

1. Locate the spool holders. Install the spool holders in the two quadrangular openings on the back. To install a spool holder, level it and insert the end into one of the openings.

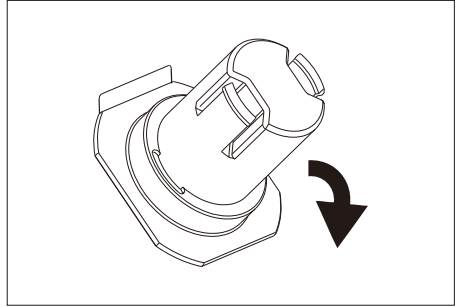

2. Turn down the spool holder to make the holder bottom cleave to the printer back.

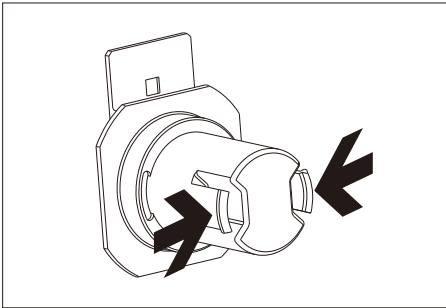

3. Squeeze the spool holder top and mount the filament spool to the holder.

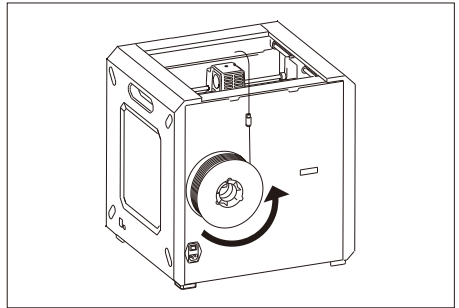

4. Secure the filament guide tube with R-shaped buckles and thread the filament through the tube. The filament spool must be oriented correctly (see above), and should feed filament from bottom to top.

Leveling Build Platform

How to change language



How to use the leveling knobs

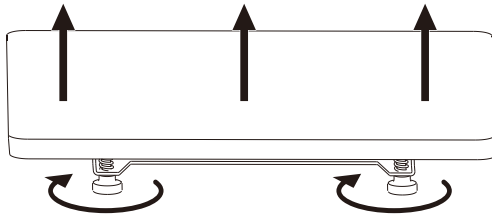

Rotate the knob clockwise

Raise the build plate to reduce the distance between the nozzle and build plate.

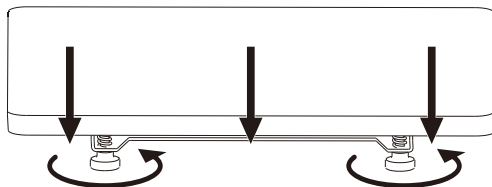

Rotate the knob Anticlockwise

Lower the build plate to increase the distance between the nozzle and build plate.

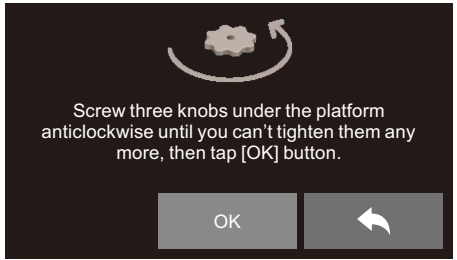
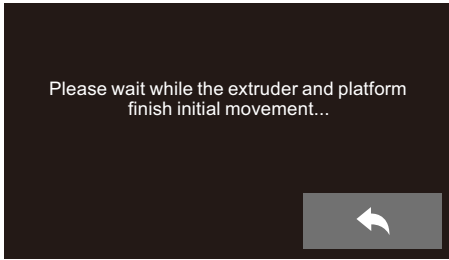

1. Tap [Tools]-[Level] on your Guider II's touch screen. Please wait while the extruder and platform complete initial movements. Then, rotate all three knobs under the platform anticlockwise until you can't tighten them anymore. Then tap [OK].

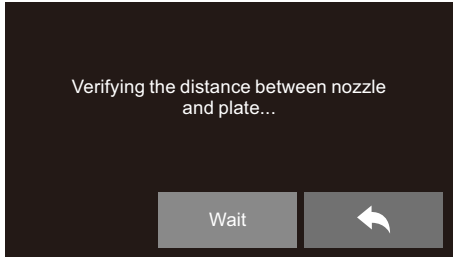
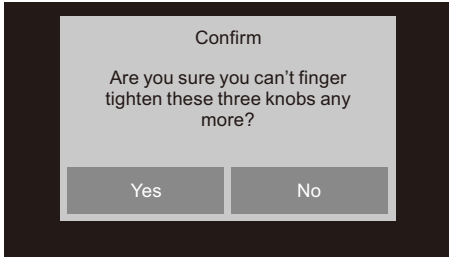

2. Tap [Yes] if you can't tighten all the nuts any more, or tap [No] to continue tightening. After selecting [Yes], the extruder will move towards the first point and the plate will move up and down to verify the distance between nozzle and plate.

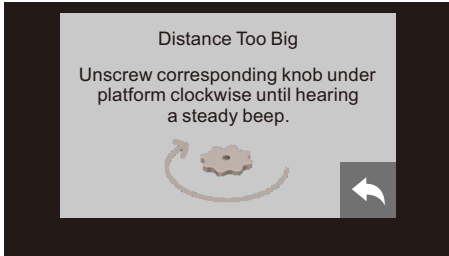

3. If the distance between the nozzle and plate is too large, rotate the knob underneath the platform clockwise until you hear a steady beep. If the distance is too small, rotate the knob anticlockwise until you hear a steady beep.

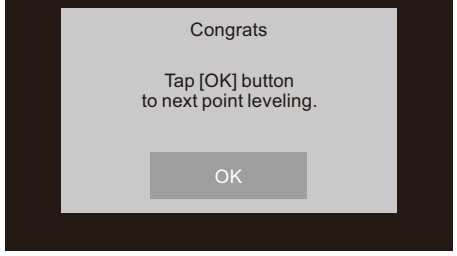
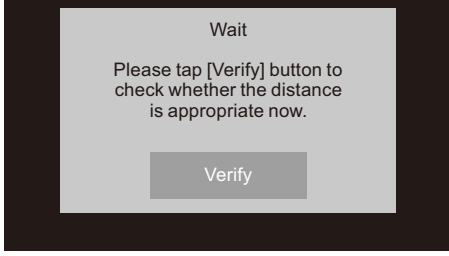

4. Then tap the [Verify] button to check whether the distance is appropriate this time. If the distance is appropriate now, tap [OK] to second leveling point. If still not, please follow the prompts to adjust again till you see [OK] button.

Repeat steps 3 and 4 to level the second and third points. Then tap [Finish] to exit.

Loading / Changing Filament

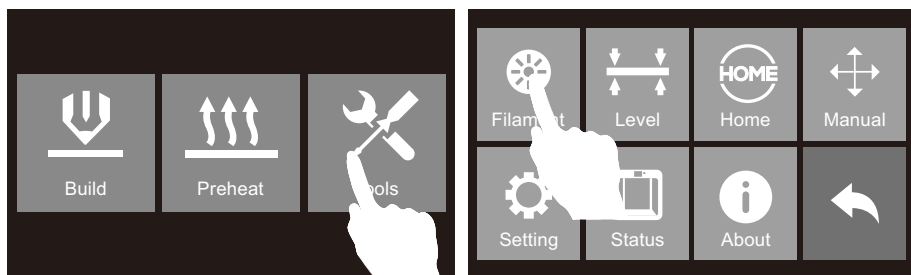

1. Tap [Tools] and then tap [Filament] and [Load] to load filament.

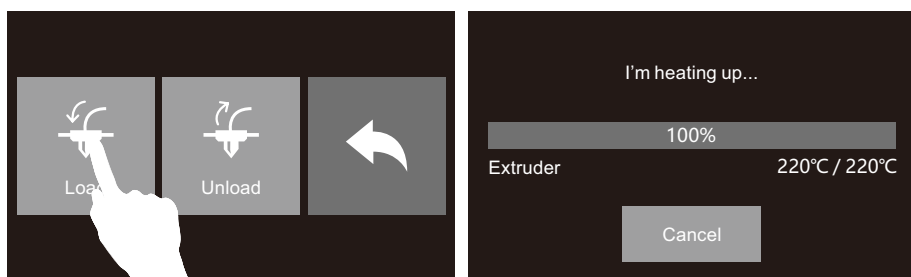

2. The extruder will automatically heat up. Once heated, filament will be drawn through the extruder. Continue extruding until the extruder provides a steady flow of filament.

Changing Filament

Do not pull out the filament with force as it will damage the gears. If the melted filament has cooled down in the extruder, please repeat the steps above.

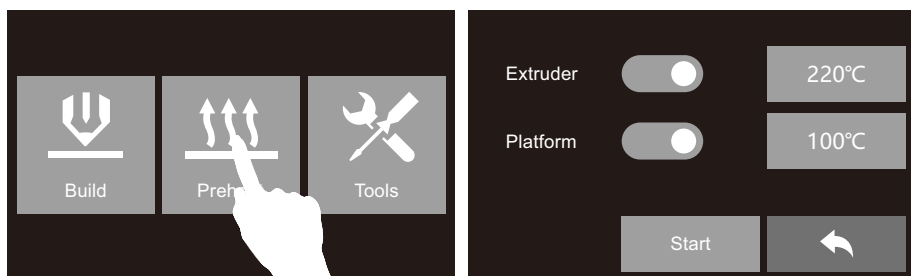

1. Tap [Preheat]--[Start] to heat up the extruder.
2. Once preheated, hold down the spring presser and pull out the filament.
3. Tap the return button, insert the new filament into the filament intake, tap [Tools]-[Filament]-[Load]. The filament will be drawn through the extruder once heated. Wait for the extruder to provide a steady flow of filament.

First Print

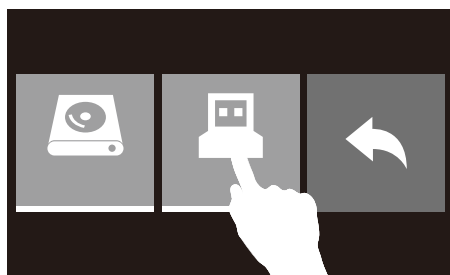
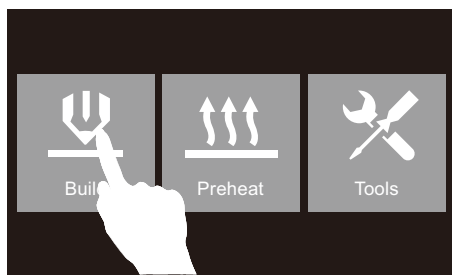

1. Please insert the USB stick into Finder. In the print interface, tap [Print]-[USB Stick].

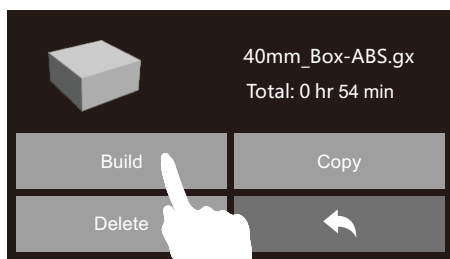

2. Select one file to print according to the filament type used, tap [Build].

3. Tap [Build].

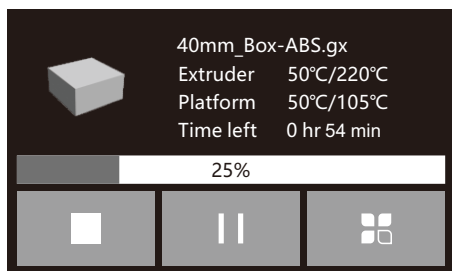

4. Once heated, the printer will start printing.

Suggestions

Ensure that the build plate has been leveled before printing.

Ensure that the filament has been loaded in an appropriate approach.

Load the filament for a while to extrude all the melted filament you printed last time out of the extruder.

Do not leave the Guider II unattended during operation.



You Tube

Scan QR to Get More
After-Sales Support



After-Sales Service: support@ff3dp.com

Tel: +86 579 82273989 Web: www.flashforge.com Add: 2/F, No.518, Xianyuan Road, Jinhua, Zhejiang, China